

GalvinCare® CP-BS Angled (75°) Wall Fixed Outlet 140mm with Forward Facing Aerator

PRODUCT CODE:
- 85156

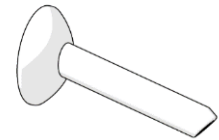

SPECIFICATIONS

- This outlet was designed to fit a wall mounted basin where the distance from the wall to the plug is greater than normal.
- Low maintenance.
- Forward facing aerator.
- Finished in bright chrome plate for easy cleaning and durability.

IMPORTANT: All outlets are tested in accordance with AS/NZS 3718 and leave our premises in good working order.

WARNINGS: Special attention to be paid on notes, photos, images, or drawings of assembly steps marked with the warning symbol.



TECHNICAL DATA

Inlet	1/2" BSP - Female	
Outlet	Aerator	
Headwork	N/A	
Working Pressure Range (kPa)	Min	50
	Max	500
Working Temperature Range (°C)	Min	5
	Max	65
Nominal Flow Rate (LPM)	6.66	
Finish	Chrome	

NOTE: Galvin Engineering continually strive to improve their products. Specifications may change without notice.

TOOLS REQUIRED

- Thread tape / sealant

DIMENSIONS

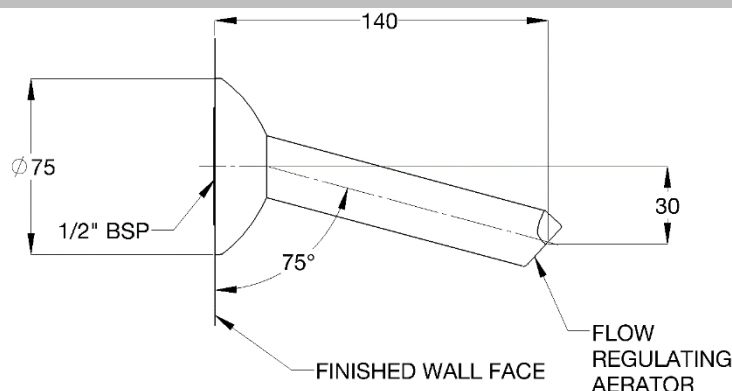

PRE-INSTALLATION

MOUNTING DETAILS

Wall Spud – Wall spud must be 1/2" BSP MI and protrude from the finished wall by no more than 15mm

Note 1) Before installation, all lines must be flushed. We recommend that a line strainer be installed prior to taps to eliminate any foreign material.

Note 2) In some situations, a male thread connection on the tap may be more suited. If so, please contact us on 1300 514 074

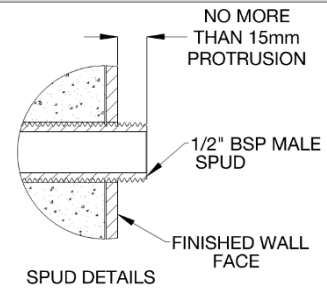

INSTALLATION

IMPORTANT: Galvin Engineering products must be installed in accordance with these installation instructions and in accordance with AS/NZS 3500, the PCA and your local regulatory requirements. Water and/or electrical supply conditions must also comply to the applicable national and/or state standards. Failing to comply with these provisions shall void the product warranty and may affect the performance of the product.

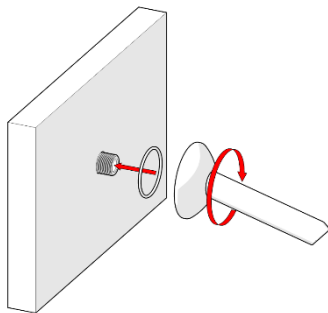

1. Fit outlet

- Apply silicone sealant or equivalent to the outlet flange and screw onto the wall spud ensuring thread tape is used.
- **Care should be taken when tightening the tapware. Hold the flange when tightening as much as possible**

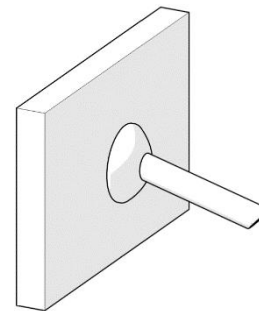

2. Secure the outlet

- Ensure that spout is pointing downwards.

3. Testing

- Once fitted, turn on the water supply and test for leaks.

TROUBLESHOOTING

PROBLEM	CAUSE	RECTIFICATION
Inconsistent flow	Blocked aerator	Remove aerator and clean
Water is not flowing from the tap	Water is turned off	Turn on the water
	Obstruction on outlet	Check if there are obstructions stopping the water flow.

WARRANTY

Galvin Engineering products are covered under our Manufacturer's Warranty. Galvin Engineering products must be installed in accordance with the installation instructions and in accordance with AS 3500 and NCC Volume Three, relevant Australian Standards and local authorities applicable to product being installed. Water and electrical supply conditions must also comply to the applicable national and/or state standards, failing to comply with these provisions may void the product warranty and affect performance of the product.

Please visit www.galvinengineering.com.au to view the full warranty, our Installation Compliance and Maintenance & Cleaning information as well as any other additional information.

Within Australia: 1300 514 074 Outside Australia: P: +61 (0)8 9338 2344

F: +61 (0)8 9338 2340

sales@galvinengineering.com.au

www.galvinengineering.com.au

ABN: 78 008 719 382

PERTH | SYDNEY | MELBOURNE | BRISBANE | ADELAIDE

